

Clarion Bathware

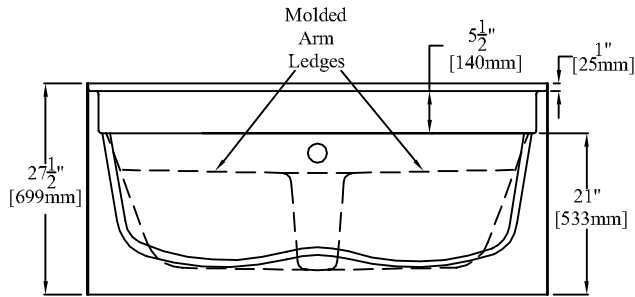

ELEVATION

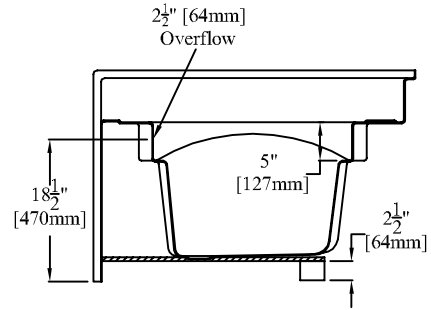

SECTION "A-A"

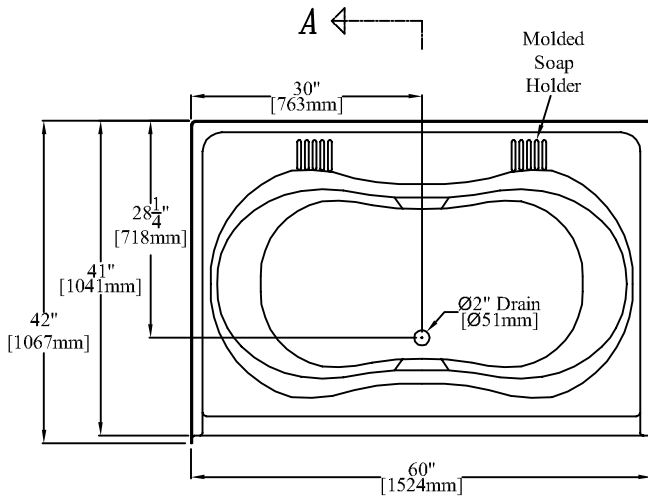

A ←

PLAN

60" [1524mm] Bathtub

FRONT CENTER DRAIN

PRODUCT SPECIFICATIONS:

- * Product complies with NAHB, HUD UM-73A, and ANSI-Z124.1.
- * Wood reinforced & slip resistant floor.
- * Integral 1" [25mm] nailing flange.
- * Factory drilled 2 1/2" [64mm] overflow.
- * Molded arm ledges in bathwell.
- * Bathwell Dimensions (At Top): W-55" [1397mm]
D-26" [660mm]
H-17" [432mm]
- * Bathwell Dimensions (At Bottom): W-41" [1041mm]
D-19 1/2" [495mm]
- * Bathwell Capacity (At Overflow): 55 Gallons [208L]
- * Water Level (At Overflow): 13 3/4" [349mm]
- * This unit is available without an overflow (Model 3100MDM).
- * This unit is available with a removable access panel (Model 3100MDA or 3100MDAM)
- * All dimensions +/- 1/4" [6.4mm]
- * Clarion Bathware reserves the right to change design and/or dimensions.
- * Dimensions are the same for RE, RS, MP, CU, and all other versions of this model.

Model 3100MD
60" [1524mm] Bathtub

Clarion
BATHWARE
44 Amsler Ave.
Shippenville, PA 16254

Phone: (814) 226-5374
Toll Free: (800) 576-9228
Fax: (814) 226-0730
www.clarionbathware.com

Signatures For Approval:

Customer: _____
Arch./Engr: _____
Contractor: _____
Cla. Engr: _____

Date:

Dwg. Name:
3100MD-CUT

Dwg. By: DJC
DATE: 1/2/07