

ACRYLIC SHOWER & TUB/SHOWER INSTALLATION

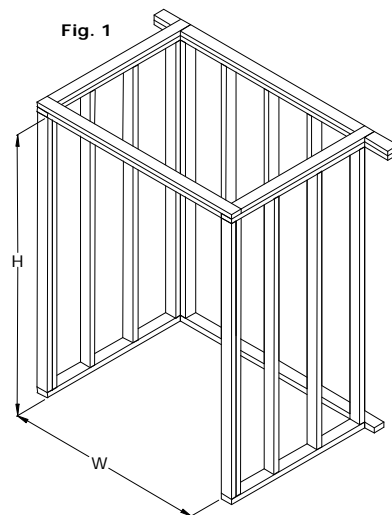

Rev. #: 12/9/08

1. Please consult all local and state building codes, and read the entire installation instructions prior to beginning the installation of this unit to ensure that the installation is performed correctly.
2. **Clarion Bathware's acrylic tub/showers are shipped with shims attached to their legs. These prevent the unit from falling over during shipment. These shims must be removed before installation. Each shim is attached to a leg using Phillips head screws. Please note that you will still need to plumb and level the tub/shower in step 4.**
3. Construct a framed pocket that is square and plumb in accordance with rough-in dimensions. (*See Figure 1 Below*) If the unit being installed is a tub/shower that has been whirlpooled, future access to the pump and parts should be considered when installing. It is advised, and is required by many local and state building codes that an access area be incorporated into the framing for a whirlpooled bathtub or tub/shower.



- * H= Height of framing pocket. This is attained by subtracting 1" from the dimensions provided on the cutsheet of the unit which shows the height of the unit.
- * W= Width of framing pocket. This is attained by subtracting 2" from the dimensions provided on the cutsheet of the unit which shows the width of the unit.
- **NOTE: Accomodations should be made in the pocket dimensions for any accessories attached to the unit.

4. Set the unit in the framed pocket and plumb and level it. First, plumb the unit by placing a level on the front posts and then level across the dam of the unit. Shims may be placed under the leveling legs to make the unit plumb and level.
5. Remove the unit from the framing. Mark and layout holes for the plumbing fixtures by marking the centers of the holes. Be sure to drill these holes from the finish side of the unit. Drill smaller holes with a sharp spade bit or hole saw. For larger holes use a saber saw with a plastic or metal cutting blade.
6. Install all plumbing fixtures for the unit, making sure not to over tighten them. Check the drain and make sure that it is sealed properly and not leaking. If the unit you are installing is a shower, you must install the unit on a bedding material of cement or casting plaster. Be sure to place a piece of plastic as a moisture barrier between the bedding material and the unit. Clarion Bathware's tub/shower combinations are designed to be self supporting. However, in cases where the occupant of the home has excessive weight, we recommend that the unit be installed on a bedding material of cement or casting plaster. The use of a bedding material however is optional when installing a tub/shower and is done at the discretion of the customer.
7. Before the bedding material cures, place the unit in the framing pocket and make sure that it is still plumb and level. As before, check for plumb on the front posts and level across the dam of the unit. When the unit is plumb and level, secure the unit to the framing with galvanized nails or screws. Secure the flanges to the studding through the pre-drilled holes. (*See Figure 2 and Figure 3 at the top of the next page*)
8. You can finish off your new tub with a variety of materials. (tile, drywall, caulking, drywall mud, plaster, wood or plastic trim).
9. Clean your new tub with a liquid detergent and warm water. Do not use any abrasive cleaners such as scouring powder, or liquid abrasive cleaners.

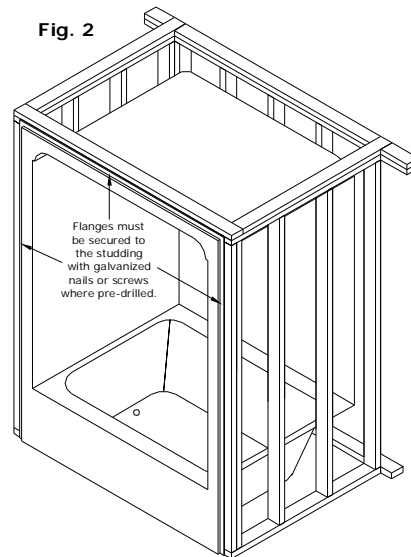
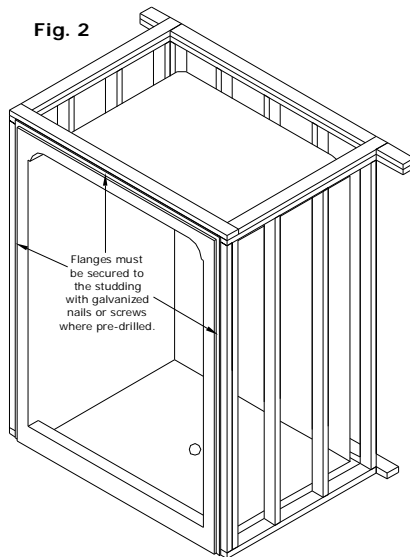

IF A BEDDING MATERIAL IS USED UNDER A UNIT; CEMENT SLURRY, THIN MORTAR MIX, PLASTER OF PARIS, OR A COMPARABLE FLOOR FILLING COMPOUND THAT IS NOT WATER SOLUBLE ARE PROPER BEDDING COMPOUNDS. WATER SOLUBLE MATERIALS, FOAM AND OTHER EXPANDING MATERIALS ARE NEVER TO BE USED AS A BEDDING COMPOUND.

NOTE: ANY BATHING WELL CAN BE WHIRLPOOLED. IT IS IMPORTANT TO DETERMINE WHERE YOU WILL HAVE ACCESS TO THE PUMP IF IT NEEDS SERVICED IN THE FUTURE. ACCESS TO THE WHIRLPOOL PUMP AND PARTS SHOULD BE CONSIDERED PRIOR TO PURCHASING AND/OR INSTALLING A WHIRLPOOLED UNIT. AN ACCESS AREA ON WHIRLPOOLS IS REQUIRED BY MANY LOCAL AND STATE CODES. ALL WHIRLPOOLS MUST BE WATER TESTED PRIOR TO BEING INSTALLED. FAILURE TO WATER TEST, CAN VOID THE WARRANTY.

IF YOU HAVE ANY QUESTIONS REGARDING INSTALLATION OF YOUR CLARION BATHWARE PRODUCT, PLEASE CALL OUR CUSTOMER SERVICE DEPARTMENT AT 1 (800) 576-9228 EXT. #818 OR BY E-MAIL AT CUSTOMERSERVICE@CLARIONBATHWARE.COM

JOB SITE INSTALLATION OF OWNER SUPPLIED ACCESSORIES

All Clarion Bathware units purchased with supplied grab bars are custom reinforced at the factory to accommodate the mounting of said bars.

Any grab bars installed on a Clarion Bathware unit at the job site must have proper reinforcement (wood support and backing plates) at all mounting areas and should comply with ANSI A117.1, Uniform Federal Accessibility Standards (UFAS) and ASTM F446 specifications for grab bars in the bathing area.

Job-site installation of third party supplied grab bars is entirely at the risk and full responsibility of the owner. Any damage to Clarion Bathware units or the property during or after grab bar installation, or any injuries due to improper installation remain the sole responsibility of said owner and cannot be attributed to Clarion Bathware, Inc.

IF YOU HAVE ANY QUESTIONS REGARDING THE INSTALLTION OF YOUR CLARION BATHWARE PRODUCT, PLEASE CONTACT OUR CUSTOMER SERVICE DEPARTMENT AT 1 (800) 576-9228 EXT. #818 OR BY E-MAIL AT CUSTOMERSERVICE@CLARIONBATHWARE.COM

*****WE SUGGEST THAT THE CUSTOMER AVOIDS USING A BATH MAT IN THE UNIT, AS IT COULD CAUSE WATER STAINS OR BLISTERING TO THE FINISH SURFACE OF THE UNIT.**

CLARION BATHWARE PRODUCTS ARE CERTIFIED TO MEET NAHB STANDARDS, HUD/FHA, BOCA, HUD UM-73A, ANSI Z124.1 AND ANSI Z124.2. FOR DETAILS, REQUEST NAHB RESEARCH CENTER CONFIRMATION.



44 Amsler Avenue Shippenville, PA 16254
(814) 226-5374 (800) 576-9228
Customer Service: Ext. #818
Fax: (814) 226-0730
www.clarionbathware.com



Premium Cast Acrylic Five (5) Year Warranty



Clarion Bathware warrants to the original purchaser and consumer that its products will be free from defects in material or workmanship when properly installed pursuant to Clarion Bathware installation instructions for the following warranty periods:

- Five (5) Year Warranty*
- (1) Premium Cast Acrylic

All accessories or purchased parts carry a (1) year warranty.

Upon inspection by an authorized representative, Clarion Bathware will repair or exchange at its sole discretion, any unit found to be defective in material or workmanship. The exchange of a unit will only be considered when Clarion Bathware has eliminated all options to restore the unit to acceptable factory condition. Exchange of a unit is limited to supplying replacement product of comparable size and style, and does not include any cost of removal or installation.

EXCEPTIONS

This warranty shall be voided if the unit is moved from its place of initial installation or is not installed in accordance with the instructions supplied by the manufacturer of the unit. Clarion Bathware will not be held responsible for any damages resulting from improper installation.

Further, this warranty does not apply if the unit has been subjected to accident, abuse, misuse, damage caused by flood, fire, or other force of nature.

Any unauthorized repair or modification to the product would render the warranty null and void.

This warranty does not apply to any equipment or accessories not installed by Clarion Bathware and Clarion Bathware will not be held liable for any results of such acts.

Clarion Bathware is not responsible for any consequential or incidental mishaps, inconvenience, time loss, incidental expense, materials or labor related to the installation of hardware or the actual tub.

The owner agrees by use of the unit that the obligations of Clarion Bathware shall not extend to contingent or indirect damage or injury to the structure of its contents, that the obligations of Clarion Bathware are limited to those set forth herein, and that no other obligations, expressed or implied, are assumed by Clarion Bathware.

The product is not recommended for outside storage.

To obtain warranty service, the Customer must give prompt notice to Clarion Bathware of any claim.

Clarion Bathware is a division of American Bath Group Inc.

**Note: Premium Cast Acrylic Five (5) Year Warranty may be superseded by specific Brand or Product Collection Warranties. Clarion Bathware Premium Cast Acrylic Five (5) Year Warranty will be the minimum length Warranty for any Premium Cast Acrylic products.