

Only **4** E-Z Steps

# 4-PIECE SHOWER & TUB/SHOWER w/ E-Z Pin INSTALLATION

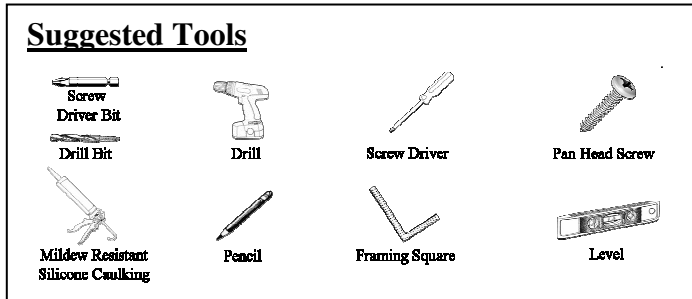

**Clarion**  
EVERYDAY LUXURY



Please consult all local and state building codes and read the entire installation instructions prior to beginning the installation of this unit to ensure that the installation is performed correctly.

Clarion Bathware's 3-piece showers & tub/showers are to be stored in a dry area prior to installation to prevent moisture from attacking the reinforcement material which could cause warpage to the unit.

Clarion's 4-piece showers and tub/showers with our E-Z Pin System have been designed to be able to be installed in the framing pocket in Only 4 E-Z Steps. However, if you wish to assemble the entire unit before installing it, you may do so. It is recommended that you disassemble and reassemble the shower or tub/shower before installation so that you can apply silicone caulking to seams of the unit. Be sure to apply the silicone caulking as described in the instructions below.

Clarion Bathware's 4-piece showers and tub/showers use factory installed E-Z Pin System to secure the unit for shipping. These E-Z Pins are riveted and bonded to the multiple piece unit to align the walls of the shower or tub/shower to the base during the installation.

**To disassemble the unit:** Remove shipping packaging, shipping pins, and wing nuts on each of the E-Z Pins (*See figure 1a*). These can be discarded as they are not used in the installation process. Set all pieces of the unit in a safe location.

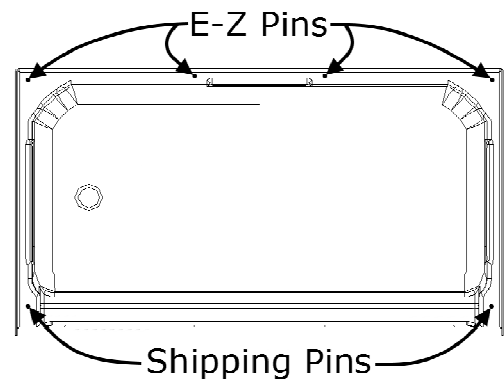

Fig. 1a

**\*\*Shipping Pins (Bolt and nut) are located in the front corners of the tub/shower unit. shipping pins and nuts are no longer needed and can be discarded.**

**Note to installer:** To simplify the installation process, the unit may be dry fitted into the pocket prior to applying silicone caulking and securing.

## **Step #1**

### ***Framing the Pocket***

Frame a square and plumb pocket to dimension of the unit. It is suggested that the floor be clear and level. If the unit being installed has a whirlpool option installed, future access to the pump and parts should be considered when installing. It is advised, and is required by many local and state building codes that an access area be incorporated into the framing for a whirlpooled tub/shower.

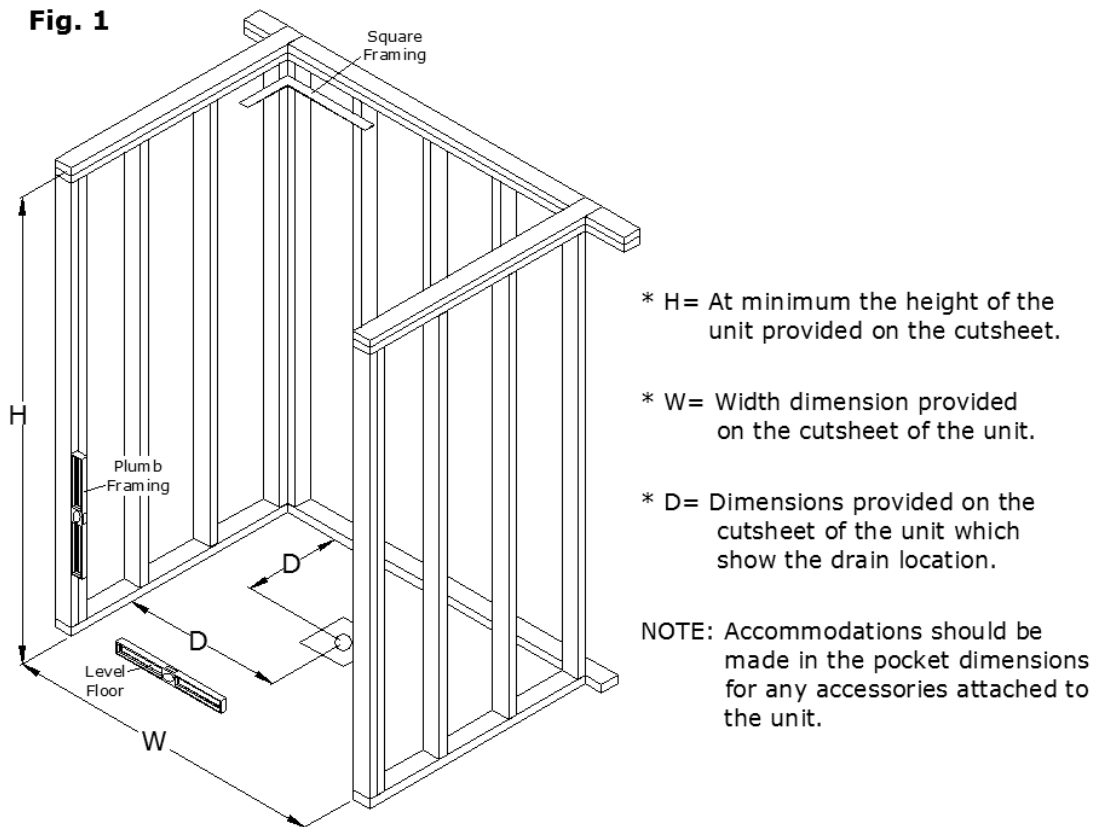

Pocket dimensions and drain location can be obtained from your retailer or at [www.clarionbathware.com/search](http://www.clarionbathware.com/search) (1) enter model number of the unit then click search, (2) select the product picture, (3) Under downloads and maintenance select the product cut sheet PDF.

## **Step #2**

### ***Installing the Base***

Set the base of the unit into the framed pocket and plumb and level it. Shims may be placed under the leveling legs to make the unit plumb and level. Install all plumbing fixtures for the unit, making sure not to over tighten them. Check the drain and make sure that it is sealed properly and not leaking. Use appropriate size shims to fill any gaps between the flange at the top of the base and the framing (see note on Fig 2). When the unit is plumb and level and any gaps are shimmed, secure the unit to the framing with galvanized nails or screws (predrilling holes is recommended). Secure the vertical flanges every 6" or as necessary to keep the flanges flush to the studding. Secure the horizontal flanges wherever they come into contact with the studding.

***(In an application where the unit is installed over wall board and will be installing a Clarion Bathware Trim Kit, for best results your fasteners will need to be flush with the nailing flange. Clarion Bathware recommends centering and counter sinking a corrosion resistance fastener on the nailing flange. Raised fasteners will result in a problematic finishing process of the trim kit.)***

## Step #2(cont.)

Clarion Bathware's products are designed to be self-supporting. However, in cases where the occupant of the home has excessive weight, we recommend that the unit be installed on a bedding material of cement or casting plaster. Use of a bedding material is required if the unit is being installed in a high use facility. (ie: dormitory, locker room, nursing home, motel, hotel, etc.) The use of a bedding material however is optional and done at the discretion of the customer. If a bedding material is used, be sure to place a moisture barrier, such as plastic, between the bedding compound and the unit.

**\*\*FOAM SHOULD NEVER BE USED AS A BEDDING MATERIAL\*\***

UNIT FLANGE ATTACHMENT  
VERTICAL FLANGE - ATTACHED 6" O.C.  
HORIZONTAL FLANGE - ATTACHED EVERY STUD

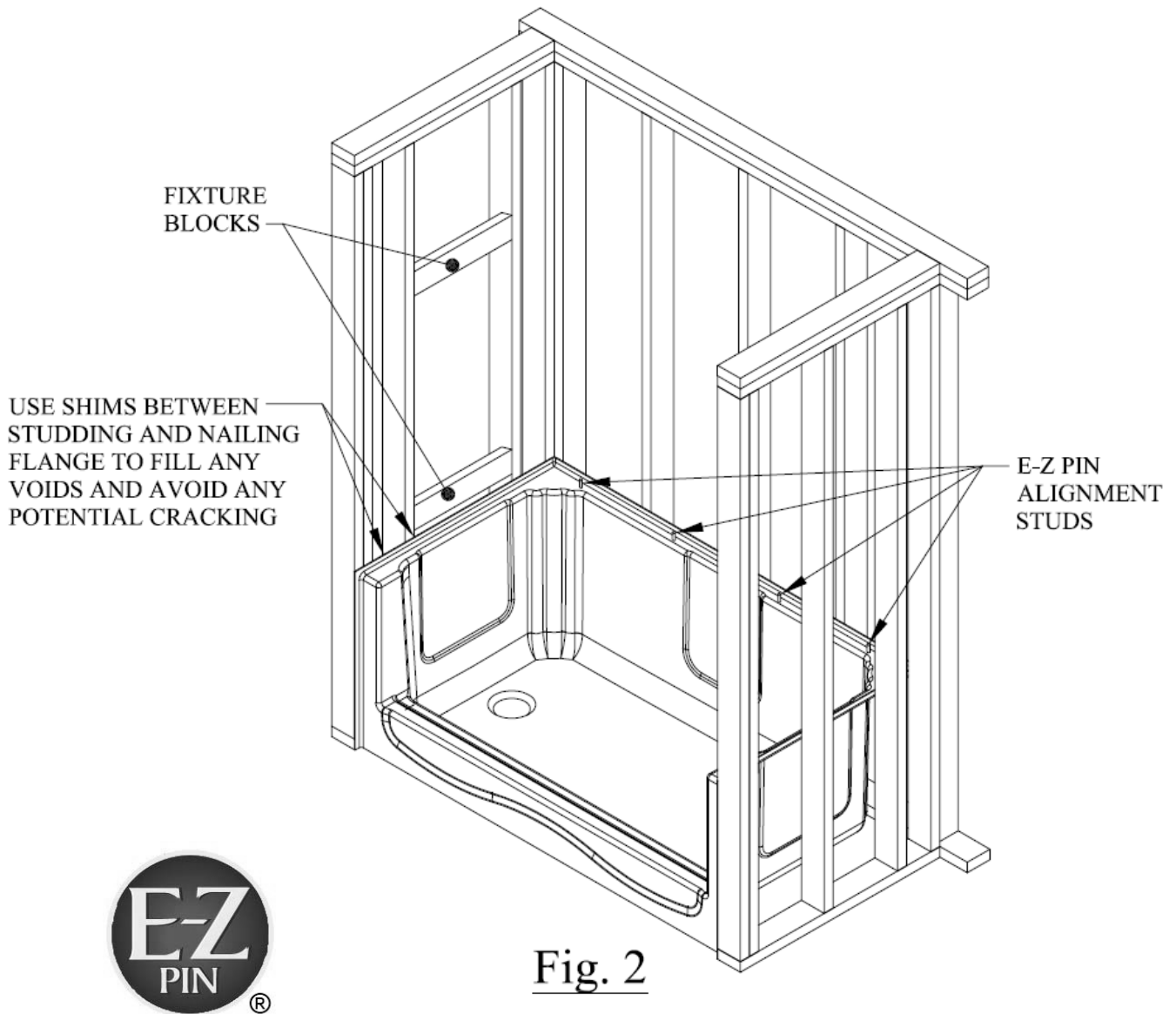
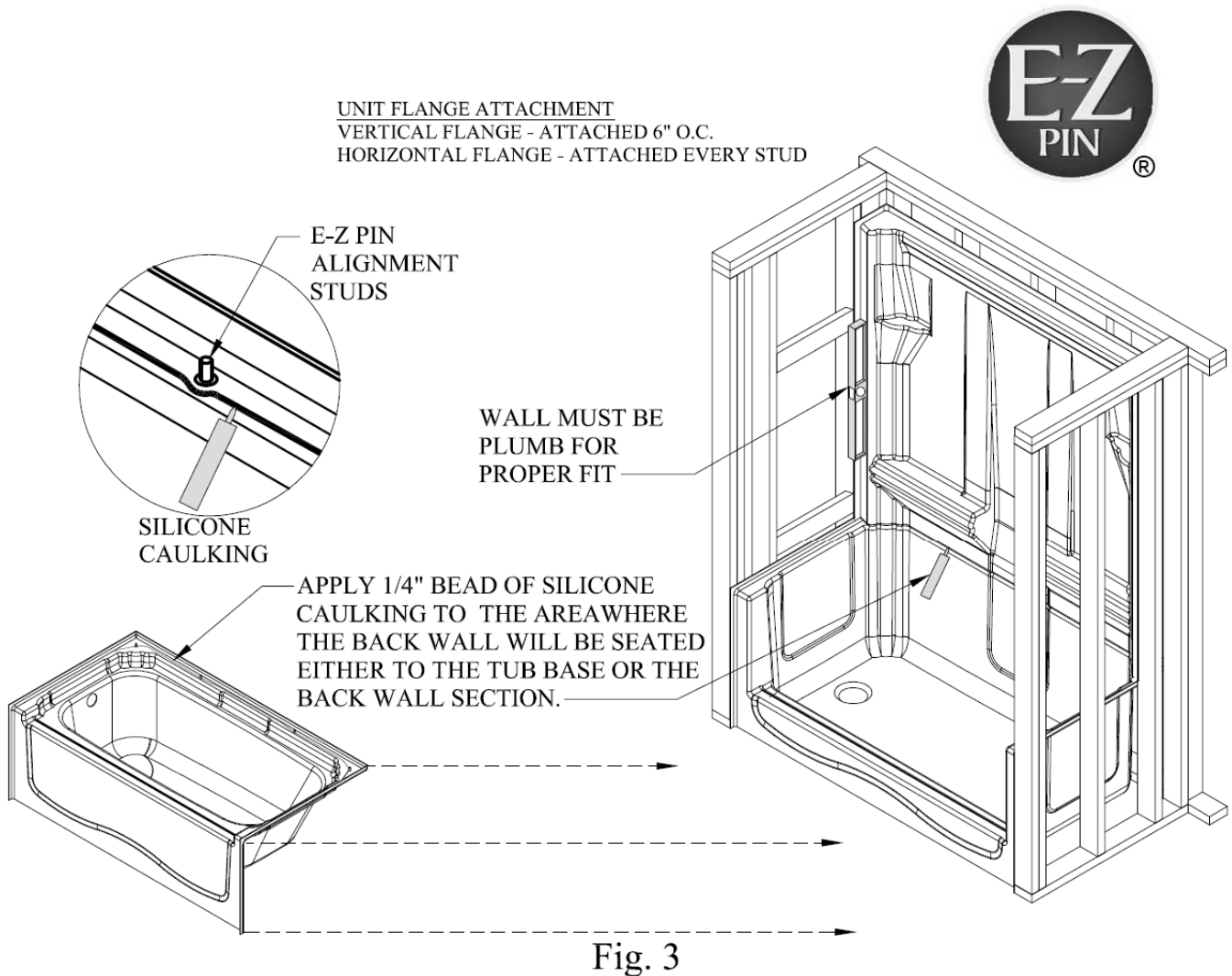

Fig. 2

### Step #3

**Figure 3**

Locate the back wall section. The E-Z Pins on the top of the base section fit through holes in the bottom of the back wall section. This will line the back wall up correctly. You can perform a dry-fit of the wall section to the base to check fit and ensure things line up and then remove panel for preparation. Before installing the back wall, clean seam, then apply a bead of silicone caulking (not latex caulking) on the seam that will be between the base and back wall. Be sure that the bead goes in front of the E-Z Pins on the base. **(Figure 3)** Guide the back wall section onto the installed base section. **Make sure that the back wall section is plumb. Use shims to get it plumb if needed. The side wall sections will not install correctly if the back wall is not plumb.** Once the back wall section is plumb and seated properly on top of the base section, secure the back wall section to the studding. Secure the vertical flanges every 6" or as necessary to keep the flanges flush to the studding. Secure the horizontal flanges wherever they come into contact with the studding. Verify again that the wall section is plumb.



## Step #4

**Figure 4**

Locate the left hand wall section of the unit. The side walls are designed to be easy to install from the front of the unit. You can perform a dry-fit of the wall section to the base to check fit and ensure things line up and then remove panel for preparation. Clean seams then apply a bead of silicone caulking (not latex caulking) on the seam that will be between the base and the side wall & the side wall and the back wall (FIG 4.1 & 4.2). As with the back wall installation, there are E-Z Pins and mating holes to guide the wall into place. Once the left side wall section is seated properly on top of the base section, secure the side wall section to the studding. Secure the vertical flanges every 6" or as necessary to keep the flanges flush to the studding. Secure the horizontal flanges wherever they come into contact with the studding.

\*\*Note: If installing the unit under drywall, see Fig4.3. Installation over drywall, see section, Fig 4.4

Repeat **Step #4** process for the right hand wall section.

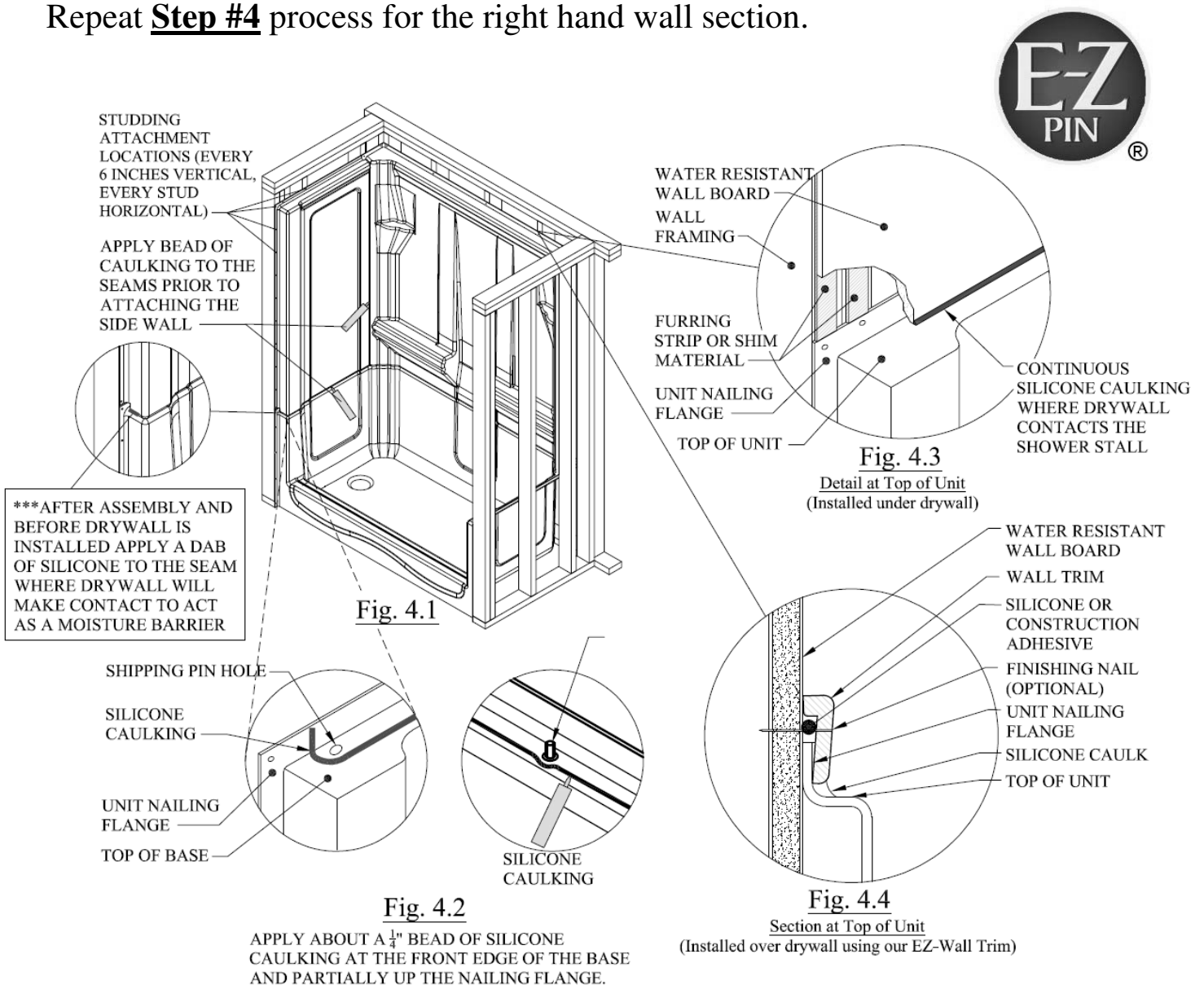

## ***Final Notes:***

You can finish off your new unit with a variety of materials which are accepted by local building codes. Some ideas are tile, drywall caulking, drywall mud, plaster, wood or plastic trim.

Clean your new tub with a liquid detergent and warm water.

Do not use any abrasive cleaners such as scouring powder or liquid abrasive cleaners.

**IF A BEDDING MATERIAL IS USED UNDER A UNIT; CEMENT SLURRY, THIN MORTAR MIX, PLASTER OF PARIS, OR A COMPARABLE FLOOR FILLING COMPOUND THAT IS NOT WATER SOLUBLE ARE PROPER BEDDING COMPOUNDS. WATER SOLUBLE MATERIALS, FOAM AND OTHER EXPANDING MATERIALS ARE NEVER TO BE USED AS A BEDDING COMPOUND.**

**NOTE: ANY BATHING WELL CAN BE WHIRLPOOLED. IT IS IMPORTANT TO DETERMINE WHERE YOU WILL HAVE ACCESS TO THE PUMP IF IT NEEDS SERVICED IN THE FUTURE. ACCESS TO THE WHIRLPOOL PUMP AND PARTS SHOULD BE CONSIDERED PRIOR TO PURCHASING AND/OR INSTALLING A WHIRLPOOLED UNIT. AN ACCESS AREA ON WHIRLPOOLS IS REQUIRED BY MANY BUILDING CODES. ALL WHIRLPOOLS MUST BE WATER TESTED PRIOR TO BEING INSTALLED. FAILURE TO WATER TEST CAN VOID THE WARRANTY.**

**IF YOU HAVE ANY QUESTIONS REGARDING INSTALLATION OF YOUR CLARION BATHWARE PRODUCT, PLEASE CALL OUR CUSTOMER SERVICE DEPARTMENT AT 1 (800) 576-9228 EXT. #818 OR BY E-MAIL AT CUSTOMERSERVICE@CLARIONBATHWARE.COM**

### **JOB SITE INSTALLATION OF OWNER SUPPLIED ACCESSORIES**

All Clarion Bathware units purchased with supplied grab bars are custom reinforced at the factory to accommodate the mounting of said bars.

Any grab bars installed on a Clarion Bathware unit at the job site must have proper reinforcement (wood support and backing plates) at all mounting areas and should comply with ANSI A117.1, Uniform Federal Accessibility Standards (UFAS) and ASTM F446 specifications for grab bars in the bathing area.

Job-site installation of third party supplied grab bars is entirely at the risk and full responsibility of the owner. Any damage to Clarion Bathware units or the property during or after grab bar installation, or any injuries due to improper installation remain the sole responsibility of said owner and cannot be attributed to Clarion Bathware, Inc.

**\*\*\*WE SUGGEST THAT THE CUSTOMER AVOIDS USING A BATH MAT IN THE UNIT, AS IT COULD CAUSE WATER STAINS OR BLISTERING TO THE FINISH SURFACE OF THE UNIT.**

CLARION BATHWARE PRODUCTS ARE CERTIFIED TO MEET NAHB STANDARDS, HUD/FHA, BOCA, HUD UM-73A, ANSI Z124.1 AND ANSI Z124.2. FOR DETAILS, REQUEST NAHB RESEARCH CENTER CONFIRMATION.



44 Amsler Avenue Shippenville, PA 16254  
(814) 226-5374 (800) 576-9228  
Customer Service: Ext. #818  
Fax: (814) 226-0730  
[www.clarionbathware.com](http://www.clarionbathware.com)

# Clarion AcrylX™ with the Strength of ArmorCore™ Lifetime Warranty



This warranty applies to all Clarion Bathware AcrylX™ with Armorcore™ base reinforcement produced after 1-23-2017.

Clarion Bathware warrants to the original purchaser and consumer that its products will be free from defects in material or workmanship when properly installed pursuant to Clarion Bathware installation instructions for the following warranty periods:

#### Lifetime Warranty

- (1) AcrylX™, Residential\* Use
- (2) CenturyStone™, Residential\* Use

#### Thirty (30) Year Warranty

- (1) AcrylX™, Commercial\* Use
- (2) CenturyStone™, Commercial\* Use

Upon inspection by an authorized representative, Clarion Bathware will repair or exchange at its sole discretion, any unit found to be defective in material or workmanship. The exchange of a unit will only be considered when Clarion Bathware has eliminated all options to restore the unit to acceptable factory condition. Exchange of a unit is limited to supplying replacement product of comparable size and style, and does not include any cost of removal or installation.

#### **EXCEPTIONS**

This warranty shall be voided if the unit is moved from its place of initial installation or is not installed in accordance with the instructions supplied by the manufacturer of the unit. Clarion Bathware will not be held responsible for any damages resulting from improper installation.

Further, this warranty does not apply if the unit has been subjected to accident, abuse, misuse, damage caused by flood, fire, or other force of nature.

Any unauthorized repair or modification to the product would render the warranty null and void.

This warranty does not apply to any equipment or accessories not installed by Clarion Bathware and Clarion Bathware will not be held liable for any results of such acts.

Clarion Bathware is not responsible for any consequential or incidental mishaps, inconvenience, time loss, incidental expense, materials or labor related to the installation of hardware or the actual tub.

The owner agrees by use of the unit that the obligations of Clarion Bathware shall not extend to contingent or indirect damage or injury to the structure of its contents, that the obligations of Clarion Bathware are limited to those set forth herein, and that no other obligations, expressed or implied, are assumed by Clarion Bathware.

The product is not recommended for outside storage.

To obtain warranty service, the Customer must give prompt notice to Clarion Bathware of any claim.

Clarion Bathware is a division of American Bath Group Inc.

\*Residential Use is considered any unit Installed in a permanent residence dwelling of Individual ownership, such as but not limited to single family home, multi-family home, or condominium. Commercial Use is considered transient lodging, such as but not limited to healthcare facility, dormitory, hotel, or apartment complex.