

# Clarion Bathware

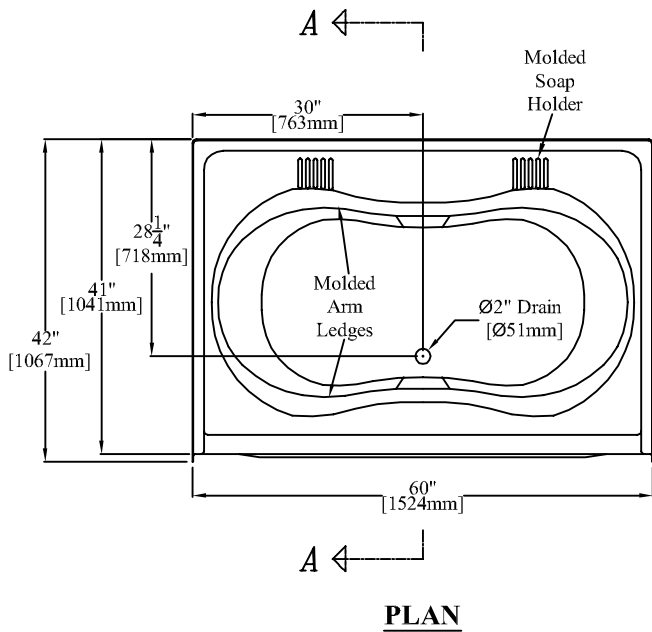
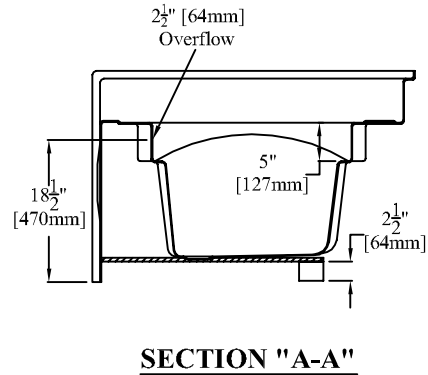
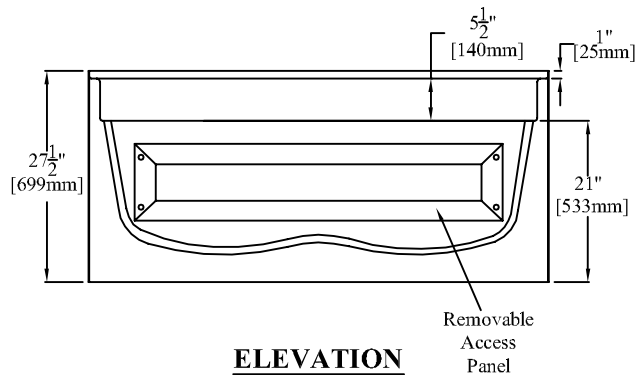

60" [1524mm] Bathtub  
With Removable Access Panel

FRONT CENTER DRAIN

## PRODUCT SPECIFICATIONS:

- \* Product complies with NAHB, HUD UM-73A, and ANSI-Z124.1.
- \* Wood reinforced & slip resistant floor.
- \* Integral 1" [25mm] nailing flange.
- \* Factory drilled 2 1/2" [64mm] overflow.
- \* Molded arm ledges in bathwell.
- \* Removable access panel.
- \* Bathwell Dimensions (At Top): W-55" [1397mm]  
D-26" [660mm]  
H-17" [432mm]
- \* Bathwell Dimensions (At Bottom): W-41" [1041mm]  
D-19 1/2" [495mm]
- \* Bathwell Capacity (At Overflow): 55 Gallons [208L]
- \* Water Level (At Overflow): 13 3/4" [349mm]
- \* This unit is available without an overflow (Model 3100MDAM).
- \* This unit is available without a removable access panel (Model 3100MD or 3100MDM)
- \* All dimensions +/- 1/4" [6.4mm]
- \* Clarion Bathware reserves the right to change design and/or dimensions.

## Model 3100MDA

### 60" [1524mm] Bathtub with Removable Access Panel

**Clarion**  
BATHWARE  
44 Amsler Ave.  
Shippenville, PA 16254

Phone: (814) 226-5374  
Toll Free: (800) 576-9228  
Fax: (814) 226-0730  
www.clarionbathware.com

Signatures For Approval:

Customer: \_\_\_\_\_  
Arch./Engr: \_\_\_\_\_  
Contractor: \_\_\_\_\_  
Cla. Engr: \_\_\_\_\_

Date:

\_\_\_\_\_  
\_\_\_\_\_  
\_\_\_\_\_  
\_\_\_\_\_

Dwg. Name:  
3100MDA-CUT

Dwg. By: DJC  
DATE: 1/2/07